

# TEMPLATE SURFACE CONTINUOUS GEARED ALUMINUM HINGE

HD2100-95"

HD5700-95"

14 CS FASTENERS

6 PAN FASTENERS

11 THRU-BOLT FASTENERS

37 BEARINGS

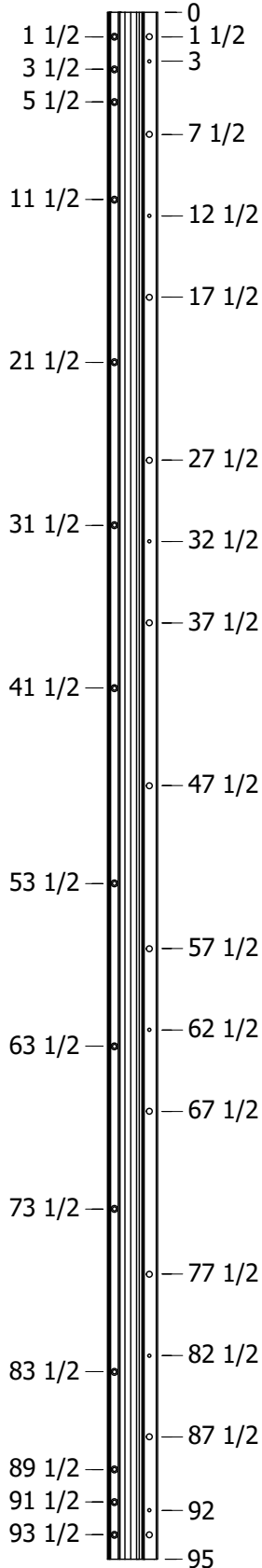

HD2100

HD5700

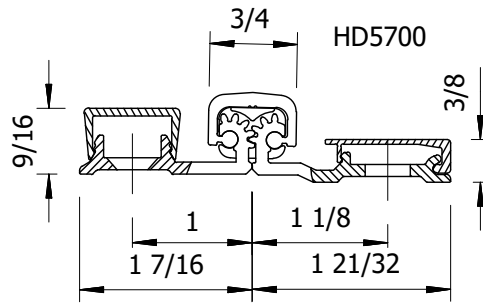
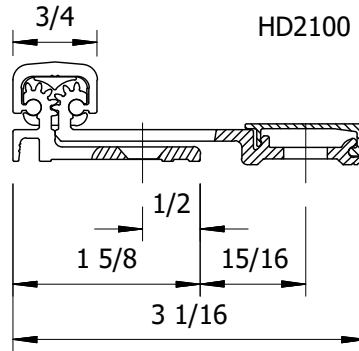
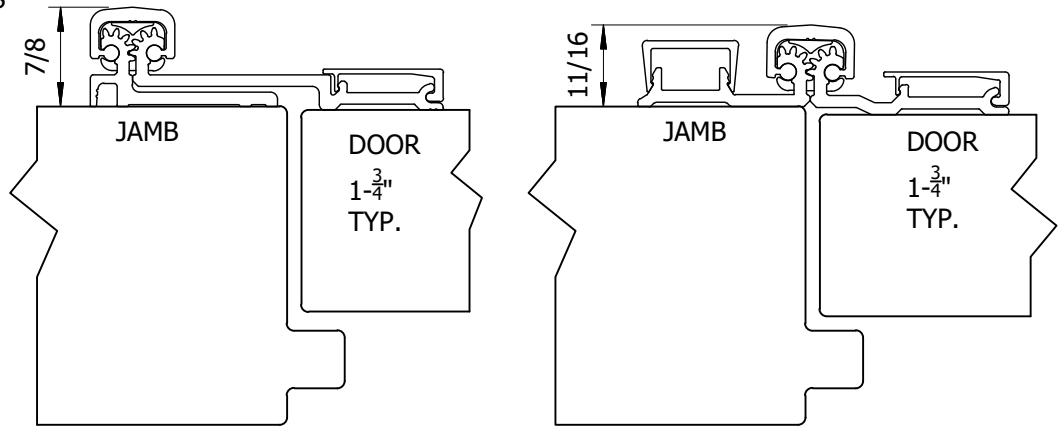

FASTENERS: #12-24 X  $\frac{11}{16}$  PH. CS. UNDERCUT TEK SCREW

#12-24 X  $\frac{11}{16}$  PH. PAN TEK SCREW

1/4-20 THRU-BOLT

REV	DESCRIPTION	DATE	APPR'D
A	ORIGINAL	6/29/2016	
REVISION HISTORY			
 <b>National Guard Products, Inc.</b> 4985 E. Raines Rd. Phone: 1 (800) 647-7874 Memphis TN 38118 Fax: 1 (800) 255-7874			
TITLE: HD2100/5700-95" TEMPLATE			
DRAWN BY: B.NORWOOD		SCALE: N/A	DATE: 6/29/2016
			TEMPLATE NO: 101666