



1038N

Adjustable Neoprene Perimeter Seal

PRODUCT CUT SHEET

PROJECT:
SUBMITTED BY:
DATE:
NOTES:

Material

Aluminum Alloy 6063, T5 Temper
Synthetic Rubber Polymer Blend: Chloroprene and EPDM
Neoprene is Black

- ▶ Very Good Abrasion Resistance, Tensile Strength and Memory
- ▶ Flame Resistant
- ▶ Moisture Resistant
- ▶ Temperature Range -20°F to 200°F
- ▶ Good Resistance to Ozone, Sunlight and Aging
- ▶ BHMA Certified to ANSI/BHMA A156.22 Performance Tests for Heat and Cold
- ▶ Adjustment Screws on 10" Centers Allow Adjustment Without Re-Positioning Mounting Location
- ▶ #6 x 3/4" or #6 x 1 1/2" Stainless Steel SMS Furnished

Finishes

1038NA Anodized Aluminum
1038NB Gold
1038NDKB Dark Bronze

Options

FATT - Fast Attach Tape

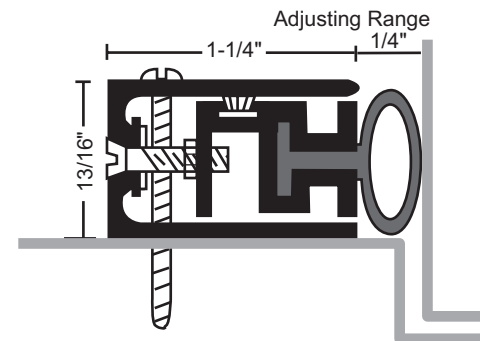
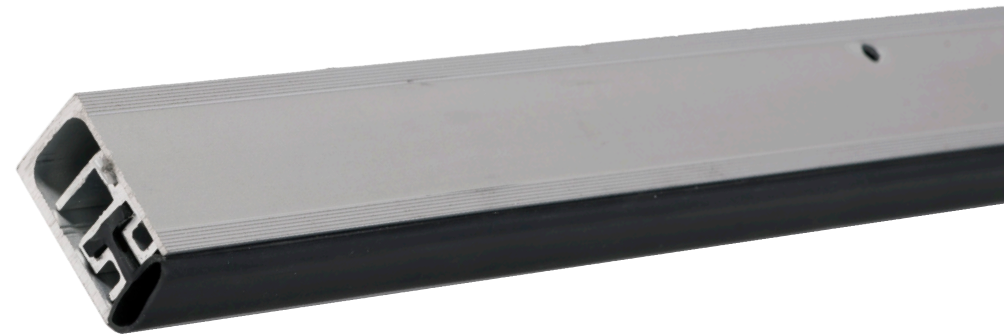

NGP-GKT-1038N-PCS-0720-A