



120NSS

Stainless Steel Neoprene Perimeter Seal

PRODUCT CUT SHEET

Material

Stainless Steel Type 304
Synthetic Rubber Polymer Blend: PVC, Nitrile Rubber (NBR), and Chloroprene Closed Cell Advanced Elastomeric Foam
Neoprene is Black

- ▶ Very Good Abrasion Resistance, Tensile Strength and Memory
- ▶ Flame Resistant
- ▶ Moisture Resistant
- ▶ Temperature Range -20°F to 200°F
- ▶ Good Resistance to Ozone, Sunlight and Aging
- ▶ BHMA Certified to ANSI/BHMA A156.22 Performance Tests for Heat and Cold
- ▶ #6 x 3/4" Stainless Steel SMS Furnished
- ▶ Screw Holes Slotted for Adjustment

Finishes

Brushed #4 Finish (US32D, 630)

Options

FATT - Fast Attach Tape



PROJECT:
SUBMITTED BY:
DATE:
NOTES:

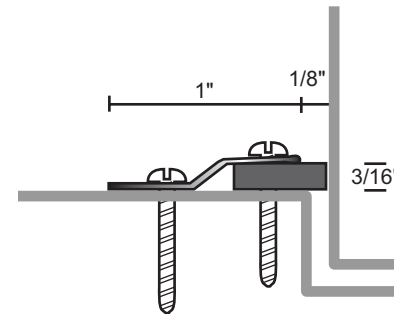

NGP-GKT-120NSS-PCS-0720-A