



159M

Magnetic Seal

PRODUCT CUT SHEET

PROJECT:
SUBMITTED BY:
DATE:
NOTES:

Material

Aluminum Alloy 6063, T5 Temper
 Thermoplastic Polymer: Polyvinyl Chloride (PVC) Formulated with an Environmentally Friendly Bio-Based Plasticizer
 Magnet Encased in Black Vinyl

- ▶ Economical
- ▶ Flame-Resistant
- ▶ Moisture-Resistant
- ▶ Temperature Range 0°F to 140°F
- ▶ Oxidative Degradation from Age and Exposure to Cold, Heat and UV Causes Hardening, Loss of Memory and Resilience, Cracking, Crazeing and Discoloration
- ▶ #6 x 3/4" Stainless Steel SMS Furnished
- ▶ Screw Holes Slotted for Adjustment
- ▶ Maximum Length 120"

Finishes

159MA Anodized Aluminum
 159MDKB Dark Bronze

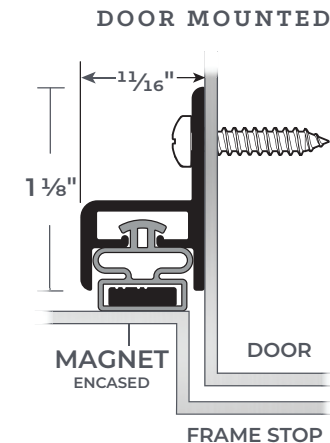
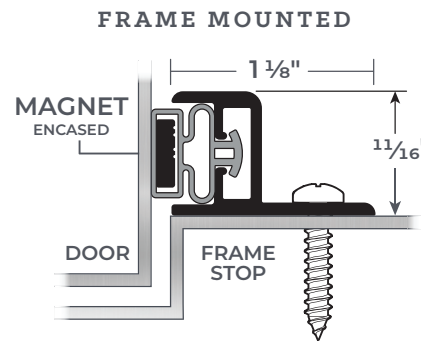

NGP-GKT-159M-PCS-0426-A

NATIONAL GUARD PRODUCTS, INC.

MEMPHIS

4985 East Raines Road
 Memphis, TN 38118

CARSON CITY

3689 Arrowhead Drive
 Carson City, NV 89706

Fax: (800) 255-7874

Email: info@ngp.com

Quotes: quotes@ngp.com

Orders: orders@ngp.com

ngp.com
 1-800-NGP-RUSH