



15N

Neoprene Door Shoe

PRODUCT CUT SHEET

PROJECT:
SUBMITTED BY:
DATE:
NOTES:

Material

Aluminum Alloy 6063, T5 Temper
Synthetic EPDM Rubber in Polypropylene Thermoplastic Matrix
Color is Black

- ▶ Very Good Abrasion Resistance, Tensile Strength and Memory
- ▶ Flame-Resistant
- ▶ Moisture-Resistant
- ▶ Temperature Range -20°F to 200°F
- ▶ Good Resistance to Ozone, Sunlight and Aging
- ▶ BHMA Certified to ANSI/BHMA A156.22 Performance Tests for Heat and Cold
- ▶ #6 x 3/4" Stainless Steel SMS Furnished
- ▶ Screw Holes Slotted for Adjustment

Finishes

15NA Anodized Aluminum
15NDKB Dark Bronze

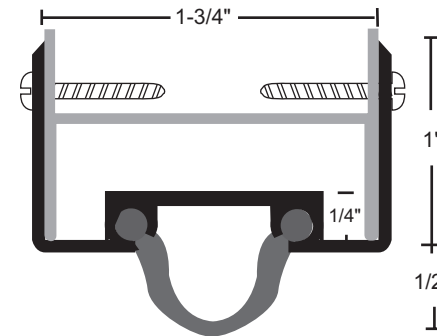

NGP-GKT-15N-PCS-1123-A

NATIONAL GUARD PRODUCTS, INC.

MEMPHIS

4985 East Raines Road
Memphis, TN 38118

CARSON CITY

3689 Arrowhead Drive
Carson City, NV 89706

Fax: (800) 255-7874
Email: info@ngp.com

Quotes: quotes@ngp.com
Orders: orders@ngp.com

ngp.com
1-800-NGP-RUSH