



170S

Concealed Fastener Silicone Perimeter Seal

PRODUCT CUT SHEET

Material

Aluminum Alloy 6063, T5 Temper
Synthetic Rubber Polymer: Siloxane
Silicone is Black

- ▶ Excellent Flexibility and Memory
- ▶ Flame Resistant
- ▶ Moisture Resistant
- ▶ Temperature Range -100°F to 500°F, Remains Flexible at Extreme Temperatures
- ▶ Excellent Resistance to Ozone, UV and Aging
- ▶ Recommended for Areas Using FM200 or Halon Fire Suppression Systems
- ▶ BHMA Certified to ANSI/BHMA A156.22 Performance Tests for Heat, Cold, Air Infiltration and Smoke Infiltration
- ▶ Snap-On Cover Conceals Screw Heads for Clean Appearance
- ▶ #6 X ¾" Stainless Steel Sheet Metal Screws Furnished
- ▶ Screw Holes Slotted for Adjustment

Finishes

170SA Anodized Aluminum
170SB Gold Aluminum
170SDKB Dark Bronze

Options

FATT - Fast Attach Tape



PROJECT:
SUBMITTED BY:
DATE:
NOTES:

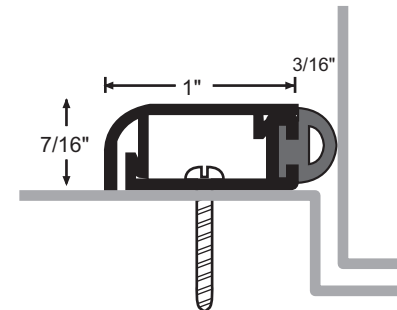

NGP-GKT-170S-PCS-1120-A