



# 225SA

## Silicone Mortise Automatic Door Bottom

### PRODUCT CUT SHEET

PROJECT:
SUBMITTED BY:
DATE:
NOTES:

#### Material

Aluminum Alloy 6063, T6 Temper  
 Synthetic Rubber Polymer  
 Silicone Is Black

- BHMA Certified to ANSI/BHMA A156.22, 1,000,000 Cycle Test-Grade 1
- BHMA Certified to ANSI/BHMA A156.22 Performance Tests for Heat and Cold
- Excellent Flexibility and Memory
- Flame-Resistant
- Moisture-Resistant
- Temperature Range -81°F to 300°F, Remains Flexible at Extreme Temperatures
- Excellent Resistance to Ozone, UV and Aging
- Recommended for Areas Using FM200 or Halon Fire Suppression Systems
- Use with a Threshold for Maximum Sealing Capability
- Nylon Brush Recommended for Carpet Applications Where No Threshold is Provided
- Specify Exact Net Length Required to Avoid Field Sizing
- Furnished 1/2" Shorter Than Ordered to Fit Within Net Door Size. (i.e. 36" is Furnished 35 1/2")
- ADB's from 12" to 18" Can be Cut Down 1/2". ADB's 20" and Over Can be Cut Down up to 1 1/2"
- Black Plastic End Caps Furnished Standard
- Minimum Length 11 1/2", Maximum Length 60"
- Mortise Required 5/8" x 1 1/2"
- 3/4" Max Drop
- Non-Handed

**Finish**  
 Anodized Aluminum

**Options**  
 Lead Insert Available for Radiation Shield - Specify 'Lead Lined'

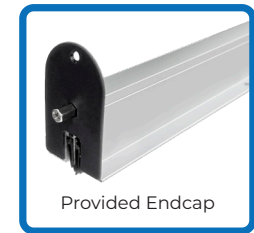
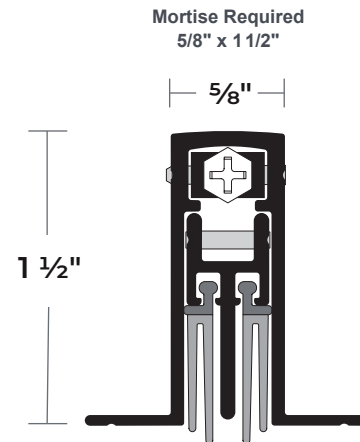
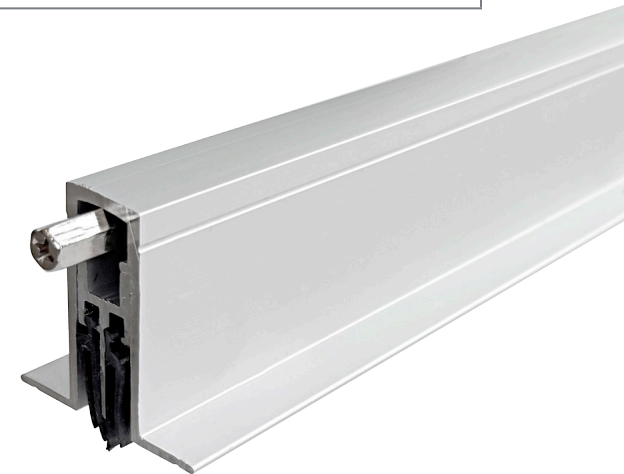

Provided Endcap

NGP-GKT-225SA-PCS-0426-A

#### NATIONAL GUARD PRODUCTS, INC.

**MEMPHIS**  
 4985 East Raines Road  
 Memphis, TN 38118

**CARSON CITY**  
 3689 Arrowhead Drive  
 Carson City, NV 89706

**Fax:** (800) 255-7874  
**Email:** info@ngp.com

**Quotes:** quotes@ngp.com  
**Orders:** orders@ngp.com

**ngp.com**  
 1-800-NGP-RUSH