

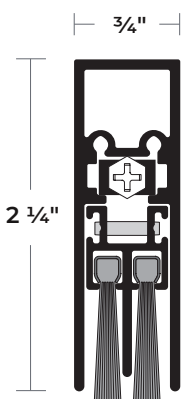

## INSTALLATION INSTRUCTIONS

# 680

Heavy Duty Automatic Door Bottom



**BHMA**  
CERTIFIED

See [ngp.com](http://ngp.com) for All Applicable Certifications for this Product.

### Hand the ADB prior to cutting and installation

Door Bottom is handed for RH doors from the factory; plunger is on the hinge side when mounted on the push side of the door. Remove the #4 x 1/2" spring retaining fastener from the back side of the ADB, which allows you to remove the spring and bar assembly and install from the opposite side for LH doors; do not reinstall fastener if the ADB needs to be cut to size.

### Cutting the ADB Down to fit Door

1. Remove drop bar and spring assembly from case, pull assembly out from plunger (adjusting nut) side prior to cutting the ADB.
2. For single doors, cut 1/8" shorter than distance between stops on frame. For pairs, cut 1/16" shorter than distance between stop on frame and meeting edge of door. ADB's from 12" to 18" can only be cut down 1/2". ADB's 20" and over can be cut down up to 1 1/2".
3. Spring assembly and drop bar should be removed from case prior to cutting case down.
4. File or sand any burrs from cutting the ADB case to length.
5. Sizing the Bar & Spring Assembly.
6. Remove the rubber or brush inserts from bar and spring assembly.
7. Cut bar 1/4" (6mm) less than case width. Insert the bar and spring assembly into the ADB case, from the hinge side of door, spring blocks slide into upper cavity, bar slides below, until hole in spring assembly con-block lines up with countersunk hole for #4 x 1/2" fastener, install fastener until head is flush with case. Push the bar into case until the bar stops, bar should be slightly in-set at both ends of the case.

### Mounting ADB to Door

1. Rubber or Brush insert should be removed, prior to mounting ADB (slide out from plunger end).
2. Install the ADB on bottom of door, with the plunger (adjusting nut) on the hinge side.
3. With the door closed align bottom of ADB case flush with bottom of door and 1/16" clearance at each end using shims to hold the ADB into position.



[ngp.com](http://ngp.com)  
1-800-NGP-RUSH

FAX:  
(800) 255-7874

QUOTES:  
[quotes@ngp.com](mailto:quotes@ngp.com)

ORDERS:  
[orders@ngp.com](mailto:orders@ngp.com)

*Continued on back*



# INSTALLATION INSTRUCTIONS

Continued from front

## 680

Heavy-Duty  
Automatic Door Bottom

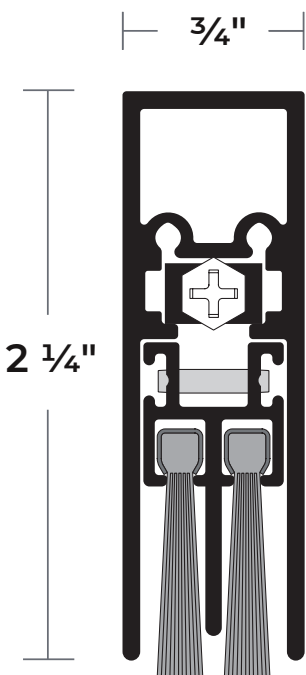

4. Mark screw holes, drill a pilot hole, using a  $\frac{9}{64}$ " (3.57mm) drill bit (**Drill Holes Straight**).
5. Insert fasteners straight, do not angle screws, tighten fasteners in place.

**Install End Plates (plate with hex hole is used on plunger side, plate without hex hole is used on lock edge of door).**

1. Install metal end plate on lock edge of door.

### Install Door Seals

1. Slide (2 ea.) seals into drop bar from the plunger end, (**ensure the bar is still flush with the case on the plunger side**) until making contact with end plate on lock edge of door. On plunger side, mark seals using a marker or pencil, flush with edge of door, pull seal out of drop bar about 6" and cut along mark. Rubber seals may be cut with scissors. Brush seals should use side cutters to crimp the case as it cuts, this will prevent the nylon filament from falling out.
2. Once seals are cut and pushed back in place, set plunger (adjusting nut) for proper seal, to reduce drop turn adjusting nut right. To increase drop, turn adjusting nut left. Maximum drop  $\frac{3}{4}$ ".
3. Install End Plate on plunger end. Once installed depress plunger to make sure the ADB is working properly.

**Warning:** Do not over adjust the plunger (adjusting nut). It is only necessary to lightly touch or compress the insert gaskets against the sealing surface to provide proper sealing. Over adjustment can cause internal component failure; voiding the warranty.

**DO NOT Use Power Tools to adjust**

**ngp.com**  
**1-800-NGP-RUSH**

FAX: (800) 255-7874  
QUOTES: [quotes@ngp.com](mailto:quotes@ngp.com)  
ORDERS: [orders@ngp.com](mailto:orders@ngp.com)