



92TWH

Thermoplastic and Nylon Brush Extended Door Shoe

PRODUCT CUT SHEET

PROJECT:
SUBMITTED BY:
DATE:
NOTES:

Material

Aluminum Alloy 6063, T5 Temper
 Thermoplastic Polymer: Polyvinyl Chloride (PVC) Formulated with an Environmentally Friendly Bio-Based Plasticizer
 Seal with Rigid Base and Soft Vinyl Fins is Dark Brown
 Nylon Brush is Gray with Anodized Aluminum; Black with DKB

- ▶ Economical
- ▶ Flame-Resistant
- ▶ Moisture-Resistant
- ▶ Temperature Range 0°F to 140°F
- ▶ Oxidative Degradation from Age and Exposure to Cold, Heat and UV Causes Hardening, Loss of Memory and Resilience, Cracking, Crazeing and Discoloration
- ▶ #6 x 3/4" Stainless Steel SMS Furnished
- ▶ End Caps Available - Sold Separately

Finishes

92TWH A	Anodized Aluminum	Gray Brush
92TWH DKB	Dark Bronze	Black Brush

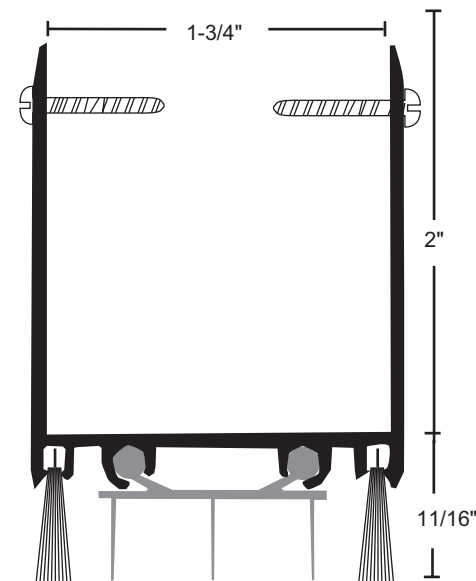

NGP-GKT-92TWH-PCS-1123-A

NATIONAL GUARD PRODUCTS, INC.

MEMPHIS

4985 East Raines Road
Memphis, TN 38118

CARSON CITY

3689 Arrowhead Drive
Carson City, NV 89706

Fax: (800) 255-7874
Email: info@ngp.com

Quotes: quotes@ngp.com
Orders: orders@ngp.com

ngp.com
1-800-NGP-RUSH