



GAP90™

Fire Door Head/Jamb Gap Solutions—Up To 90 Minutes

PRODUCT CUT SHEET

UL Certified for Head/Jamb Gaps
— Measuring Over 1/8", and up to 5/16".



- POSITIVE PRESSURE – CERTIFIED by UL to ANSI/UL10C, Complies with IBC, NFPA 80 and NFPA 252 for Application to Hollow Metal and Wood Fire Doors Rated up to 90 Minute with Excessive Door and Frame Clearances, Measuring up to 5/16"
- Restricts the Passage of Smoke
- Non-Handed
- Available in 36", 48", 84" and 96" Lengths
- An NGP Strike Shim (9275 or 9225) may also be Required for Proper Latchbolt Engagement

GAP90™

Requires Installation of ALL Components:
9945, 9400, 5075CL

GAP90DKB™

Requires Installation of ALL Components:
9945, 9400DKB, 5075B

GAP90W™

Requires Installation of ALL Components:
9945, 9400W, 5075W

9945

Steel Stop Extender

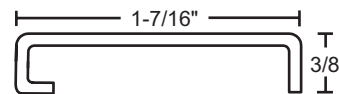

- 16-Gauge, Gray Primer Finish
- Furnished With #10 X 1" TEK SMS
- Patent No.: US9,273,510B2

5075

Self-Adhesive TPE Seal

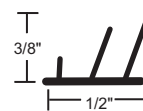

*Anti-Microbial not available in clear

5075B	BROWN
5075CL	CLEAR*
5075W	WHITE

9400

NGP-Edge® Intumescent Seal With PVC Cover

- Self-Adhesive

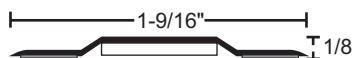

Anti-Microbial

9400	GRAY
9400DKB	BROWN
9400W	WHITE

PROJECT:
SUBMITTED BY:
DATE:
NOTES:

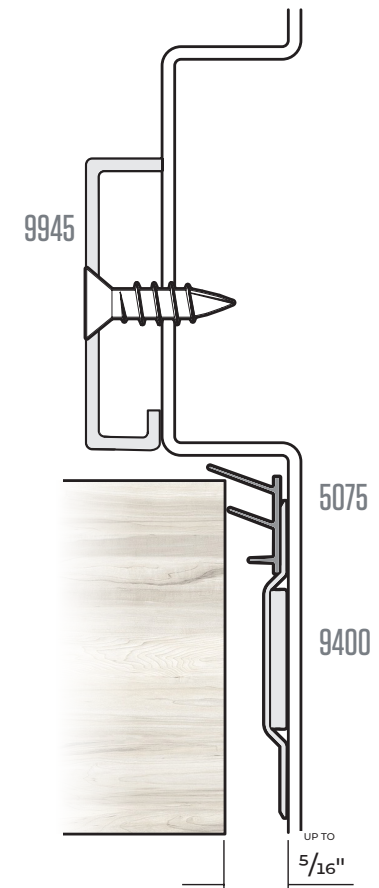

NGP-GAP-GAP90-PCS-0422-A

NGP MEMPHIS
4985 East Raines Road
Memphis, TN 38118
orders@ngp.com

NGP VEGAS
4584 Calimesa Street
Las Vegas, NV 89115
vegasorders@ngp.com

ngp.com
1-800-NGP-RUSH