



SCBY

Set of Two Soft-Close Aluminum Sliding Door Hardware

PRODUCT CUT SHEET

PROJECT:
SUBMITTED BY:
DATE:
NOTES:

For Single Sliding Aluminum Hardware Sets **BHMA**
With Doors 120 lbs. – 150 lbs. Each CERTIFIED

- ▶ Designed for Doors 120 lbs. – 150 lbs. Each
- ▶ Minimum Door Width When Using One Soft-Close Device on a Single Door is 16"
- ▶ Minimum Door Width When Using Two Soft-Close Devices for Soft-Close Both Directions on a Single Door is 31"
- ▶ Slows Travel of the Door to Softly Close
- ▶ For By-Pass and Bi-Parting Sliding Aluminum Hardware Sets. For Both Directions Order (2) Sets SCBY
- ▶ For Soft-Close Both Directions on Sidewall and Pocket Door Applications

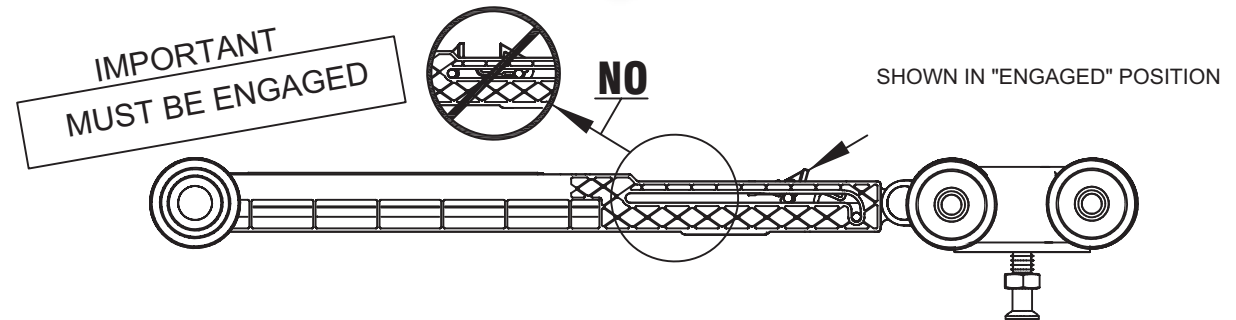
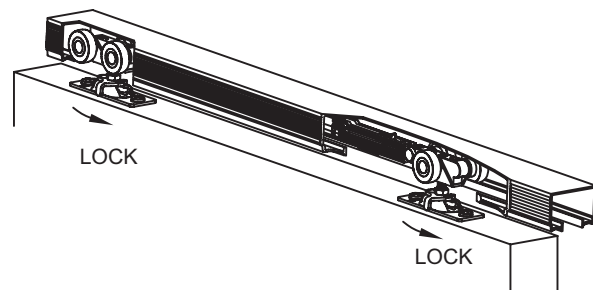

NGP-SLI-SCBY-PCS-0126-A

NATIONAL GUARD PRODUCTS, INC.

MEMPHIS
4985 East Raines Road
Memphis, TN 38118

CARSON CITY
3689 Arrowhead Drive
Carson City, NV 89706

Fax: (800) 255-7874
Email: info@ngp.com

Quotes: quotes@ngp.com
Orders: orders@ngp.com

ngp.com
1-800-NGP-RUSH