



For the complete list of Flat Track Sliding Door Hardware, the most up-to-date product information and installation instructions, scan the QR code or visit ngp.com.



SL_FT1-6, SL_FT1-6-SC SL_FT1-8, SL_FT1-8-SC

Flat Track Sliding Door Hardware – Soft Close is Included in Kits Ending in “SC”

INSTALLATION INSTRUCTION

WARNING: Must be installed into wall blocking.

If you have questions about what type of wall blocking is required, consult a structural engineer.

SL_FT1-6, SL_FT1-6-SC

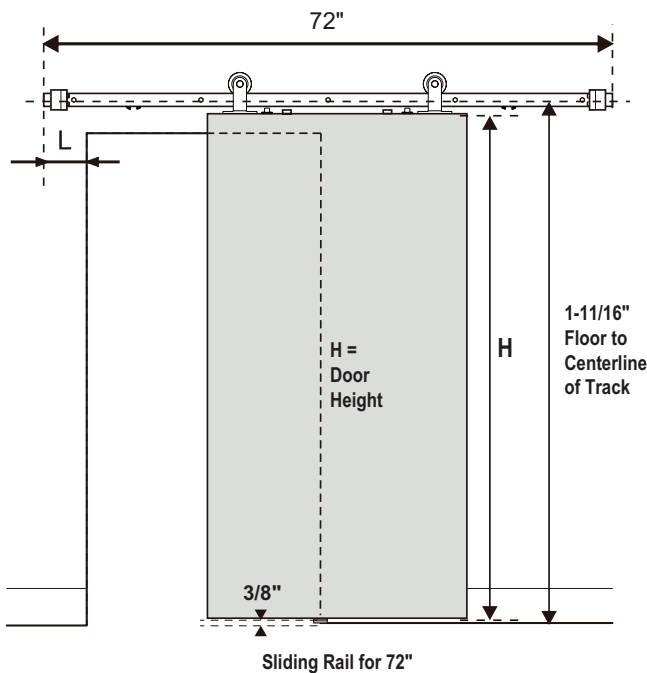

SL_FT1-8, SL_FT1-8-SC

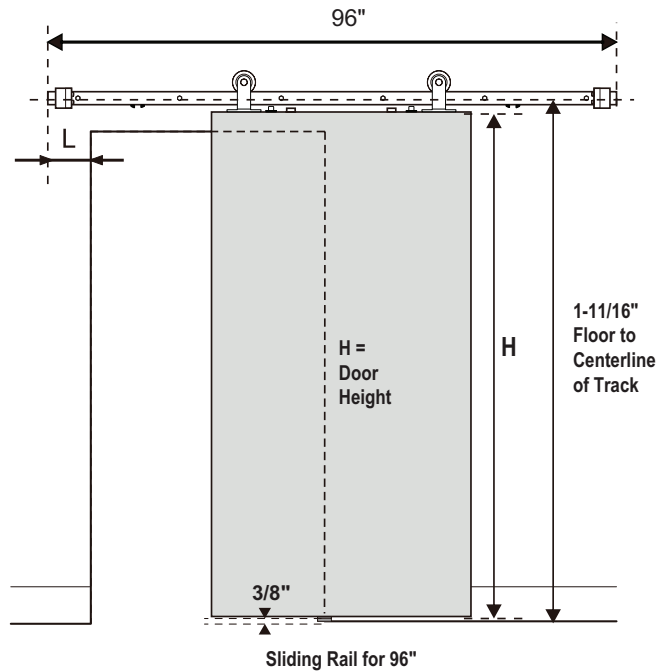

Dimensions shown: Inches (mm)

Notes:

1. "L" = Door Overlap (2" overlap recommended)
2. Minimum door overlap on guide side is 2" (51).
3. Must be installed into wall blocking. If you have questions about what type of wall blocking is required, consult a structural engineer.

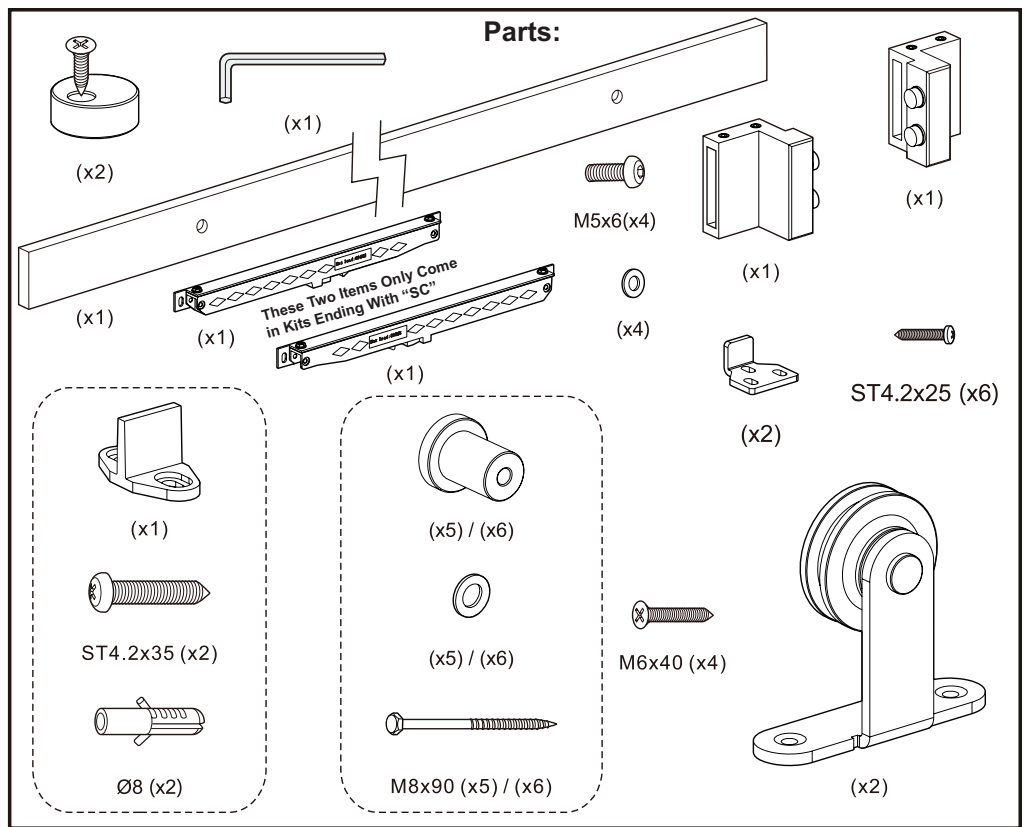
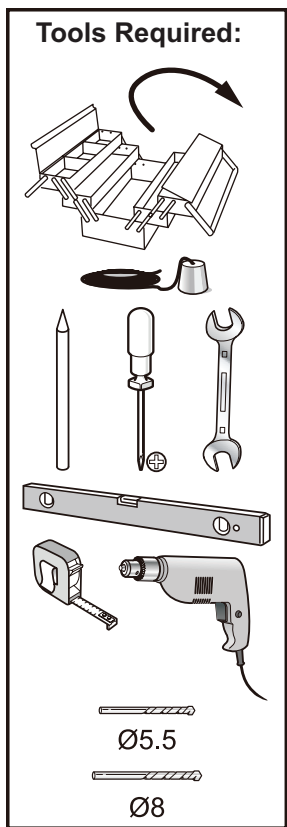

1. Using track as a template, mark wall for track fasteners. Ensure track is level.

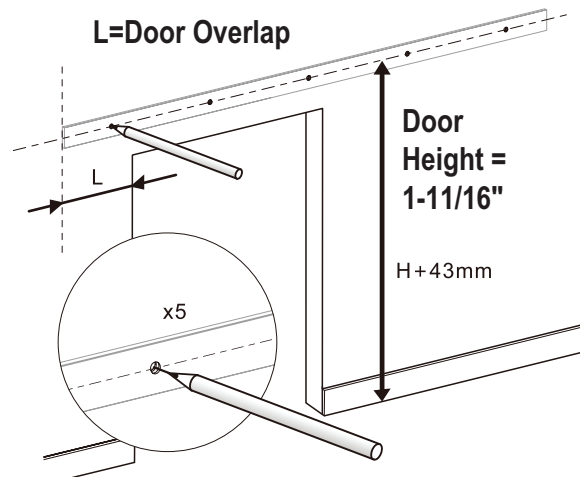

2. Pre-drill wall and blocking for track fasteners. Optional drywall spacers SL-BLFT-DWS and SL-SNFT-DWS.

If using drywall spacers: use $3/4"$ drill bit to remove drywall at bracket locations. Use appropriate thickness spacers to replace drywall removed and seat against blocking.

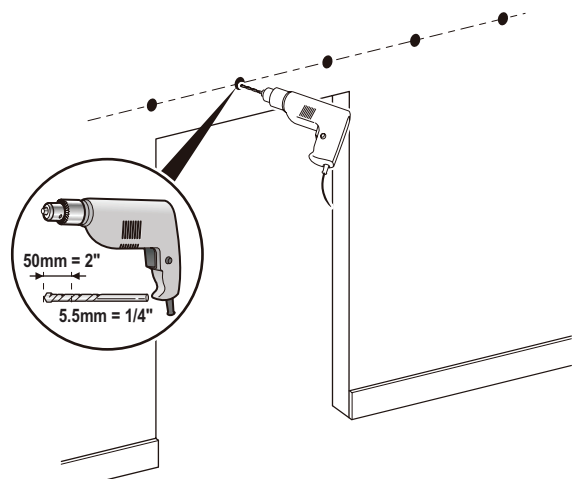

3. Install track to wall using track brackets and fasteners.

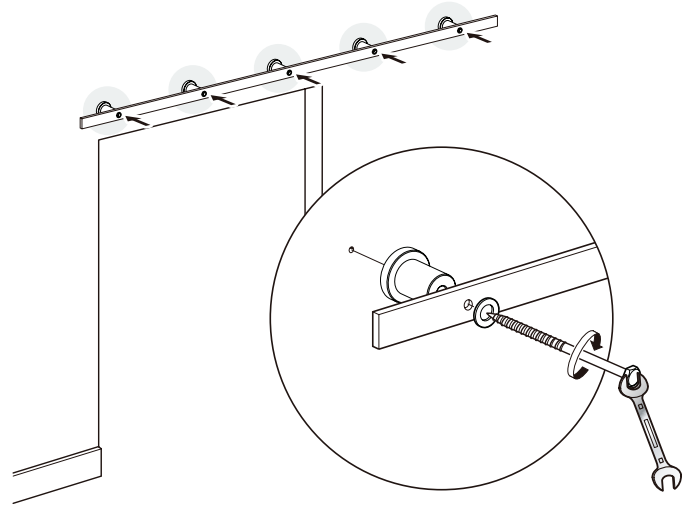

4. Using hanger as a template, mark door pre-drill in marked locations as shown, then install hangers.

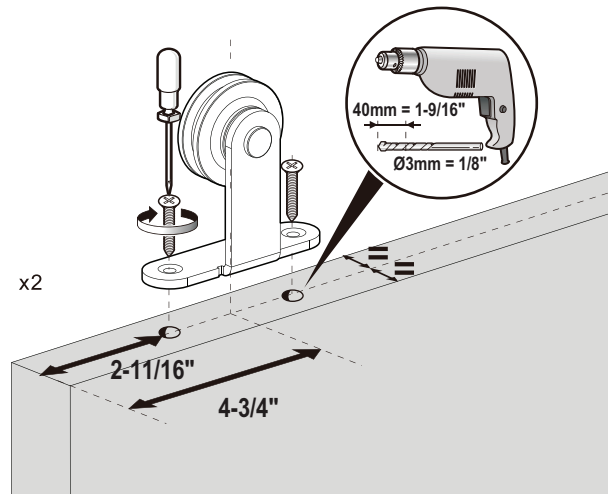

5. Install anti-rise as shown.

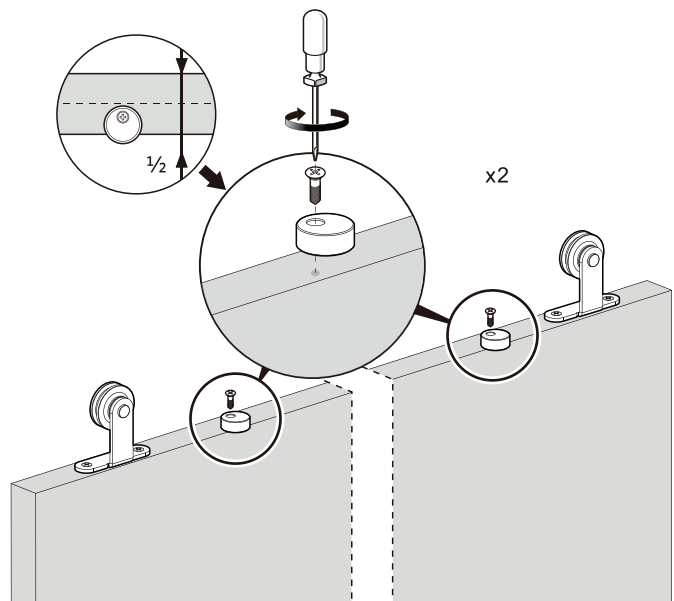

6. Lift door onto track as shown. Turn anti-rise discs so that they are under the track. This prevents the door from coming off track.

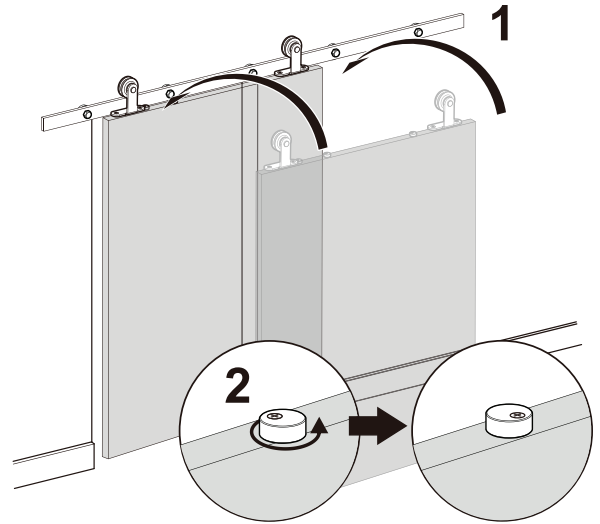

7. Install floor guide.

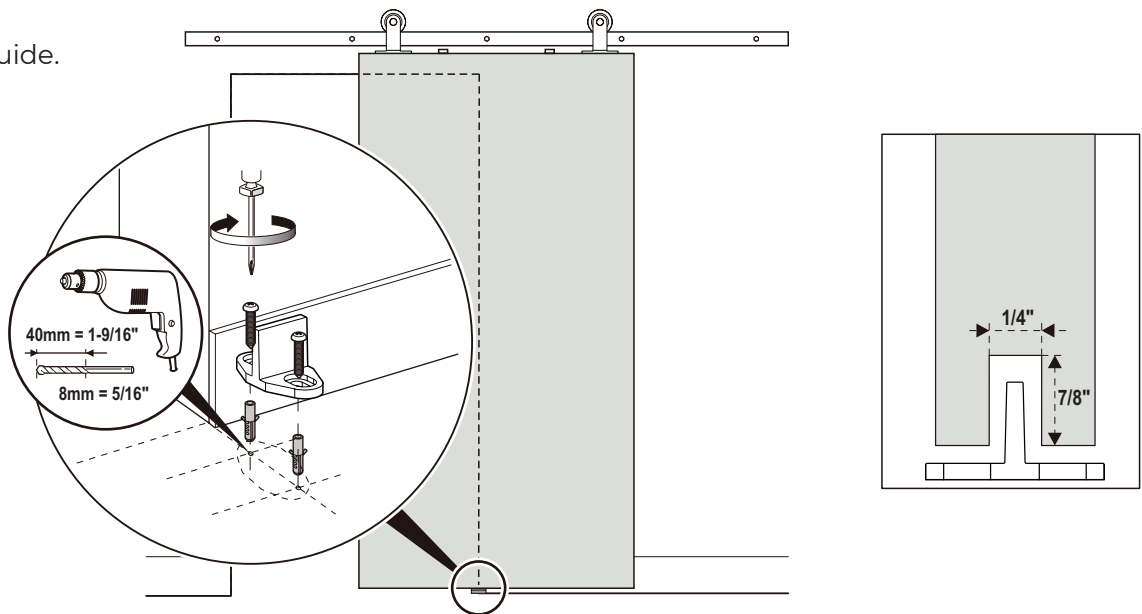

8. (If soft close is not included, skip to step 10.) Install soft close to back of track between first and second track fastener at each end of track.

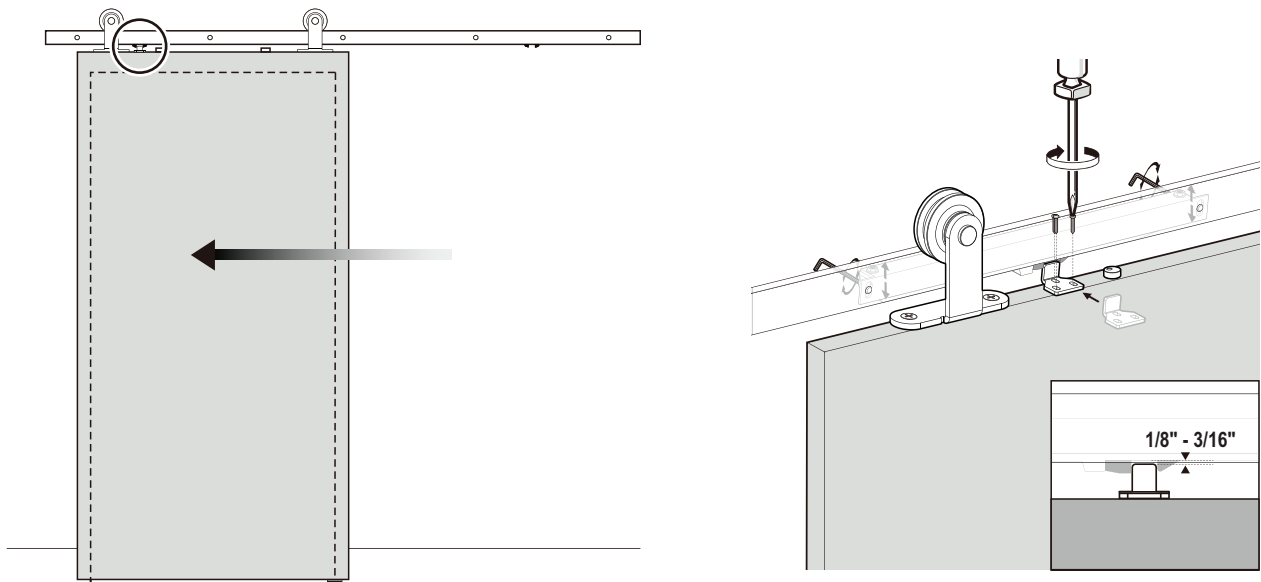

9. Install activator to door top at desired location.

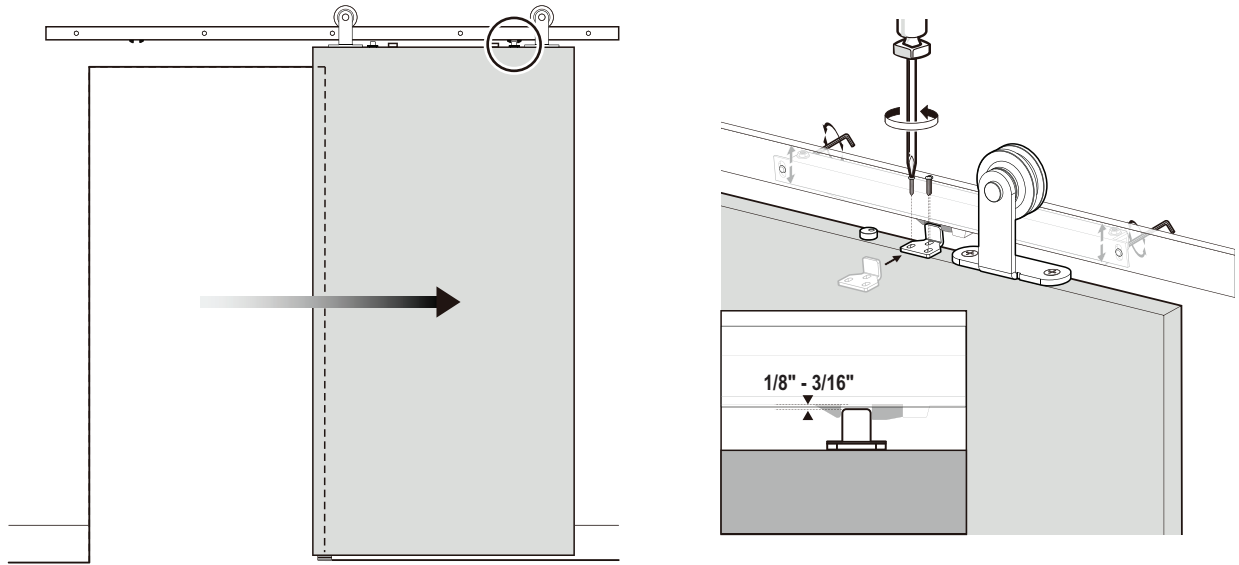

10. Adjust hard stops to desired location. Track fastener at end of track may need to be removed to slide the stop past it. Reinstall end faster after adjusting stop. Tighten stops at desired location as shown.

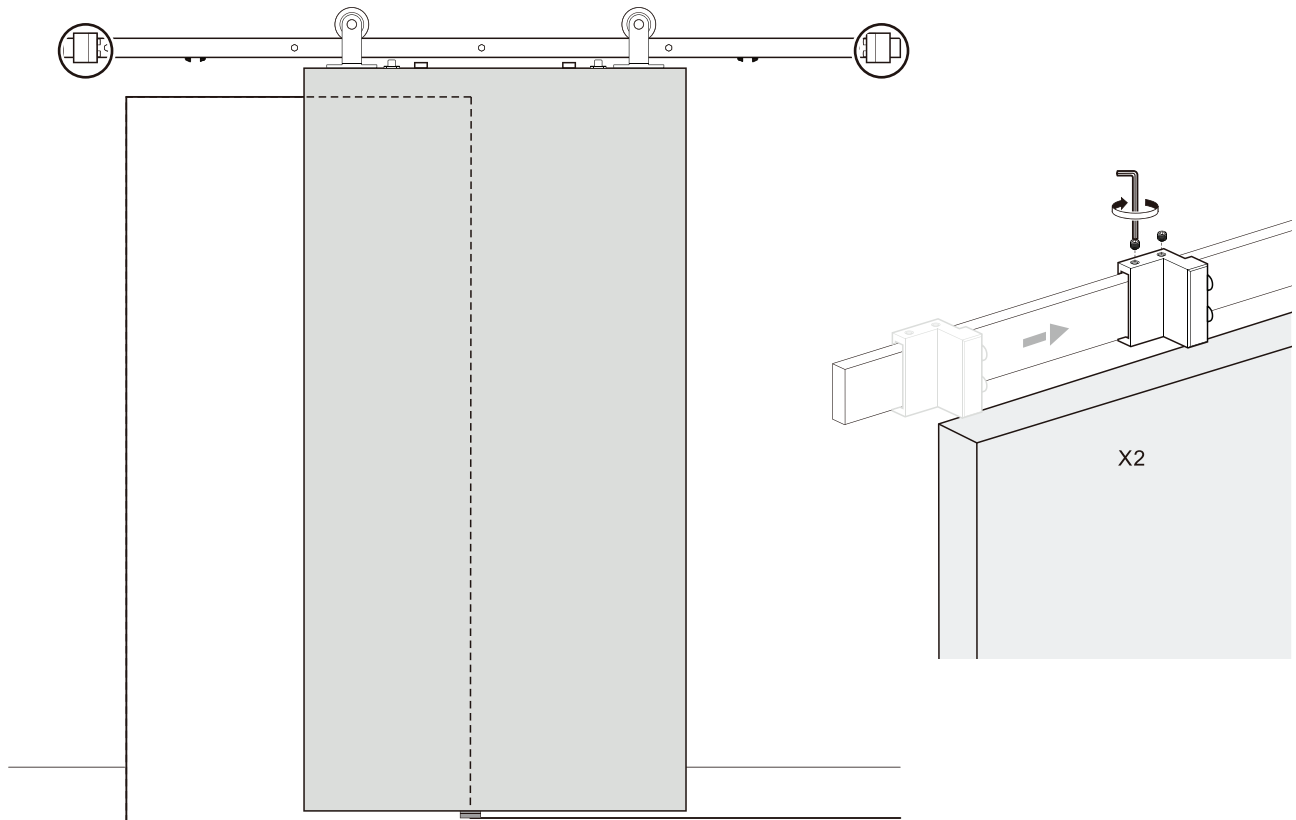



NGP-SLI-SL-FTI-PRI-0324-A



MEMPHIS | CARSON CITY

NATIONAL GUARD PRODUCTS, INC.

MEMPHIS

4985 East Raines Road
Memphis, TN 38118

CARSON CITY

3689 Arrowhead Drive
Carson City, NV 89706

Fax: (800) 255-7874

Email: info@ngp.com

Quotes: quotes@ngp.com

Orders: orders@ngp.com

ngp.com
1-800-NGP-RUSH