



SLSS2-6-SC

Stainless Steel Sliding Door Hardware — Barn Door Side Mount

PRODUCT CUT SHEET

Side Mount Round Track System — Track Length 78 3/4"

- Fits 1 3/4" Thick Door Panel
- Brushed Stainless Steel 304
- Side Wall Mount
- Nylon Coated Stainless Steel Wheels for Smooth Operation
- For Sliding Doors up to 220 lbs. Each
- Meets ADA Push Force Requirements
- 5-Year Warranty
- Order Two Sets for Bi-Parting Applications
- Soft-Close / Open Hardware is Included for Both Directions in Addition to the SLSS2-6 Complete Kit Contents

Complete Kits Include:

- (1) Track With Soft-Close
- (2) Door Stops
- (2) Hangers
- (1) Floor Guide

SLSS2-6 includes: (5) Wall Attachments

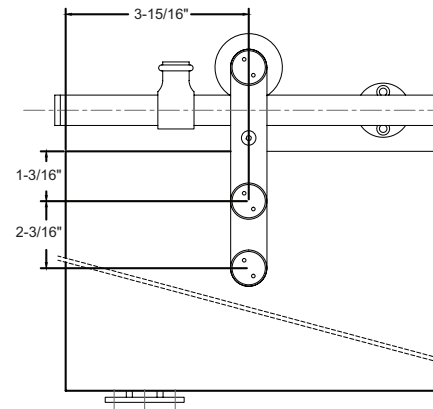
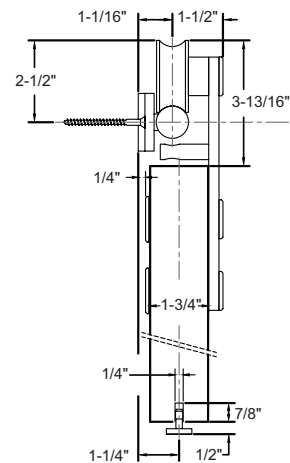

PROJECT:
SUBMITTED BY:
DATE:
NOTES:



NGP-SLI-SLSS2-6-SC-PCS-0625-A

NATIONAL GUARD PRODUCTS, INC.

MEMPHIS

4985 East Raines Road
Memphis, TN 38118

CARSON CITY

3689 Arrowhead Drive
Carson City, NV 89706

Fax: (800) 255-7874

Email: info@ngp.com

Quotes: quotes@ngp.com

Orders: orders@ngp.com

ngp.com
1-800-NGP-RUSH